

Development of MgB₂ Superconducting Coils for Nuclear Physics Applications

**DOE-NP SBIR/STTR Exchange Meeting
6-7 August 2015
Hilton Washington, DC North, Gaithersburg,
Maryland**

Matt Rindfleisch

Mike Tomsic

Jinji Yue

CJ Thong

Xuan Peng

David Doll



Development partners

BROOKHAVEN
NATIONAL LABORATORY

**Superconducting
Magnet Division**

Ramesh Gupta
Bill Sampson
Seetha Lakshmi Lalitha
Arup Ghosh
Mike Furey



Mike Sumption
Ted Collings
Milan Majoros
Guangze Li
Yuan Yang
Chris Kovacs



Hyper Tech Research
Columbus, OH, USA
42,000 sq ft facility

**And of course, our grant
sponsor: DOE NP**

Grant #DE-SC0007505

Outline

- ⌘ Motivation of SBIR project
- ⌘ Background on MgB₂ superconductors
 - Conductor properties
 - Applications
- ⌘ Phase II efforts
 - SBIR Phase II Objectives
 - 1st MgB₂ solenoid coil
 - 2nd MgB₂ coil
 - Next steps

Motivation of project (1)

- An e-lens system is currently under construction at BNL to increase RHIC luminosity.
- It consists of room temperature copper and superconducting solenoids
- The optimization of the system is limited by the power consumption of the room temperature solenoids (currently limited to 1/2 MW).
- The proposed MgB₂ magnets can significantly increase the field to significantly improve the design and performance of the e-lens system while consuming little power.

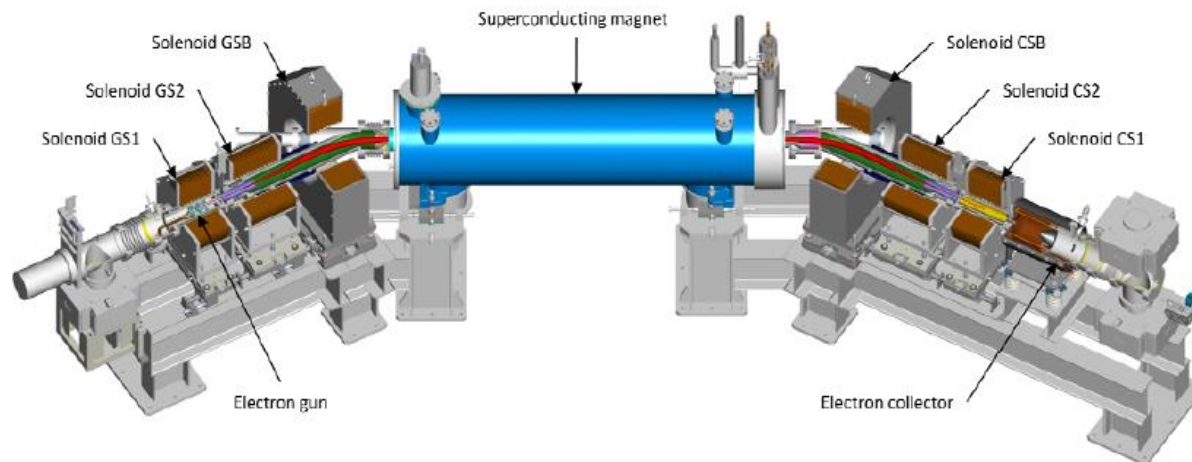

Motivation of project (2)

- A RHIC luminosity upgrade was endorsed by Nuclear Science Advisory Committee (NSCA) in its report published in 2007. The e-lens project has a goal to increase luminosity and reduce loss of the circulating proton beam in RHIC with head-on beam-beam compensation
- The size (σ of Gaussian distribution) of the beams in the interaction region should be adjustable within range of at least (0.28 - 1.0) mm.
- An electron beam with current around 1.0 A and energy 5-10 keV will be injected in the interaction region using dipole components of tilted solenoids. The electron beam is fully confined by the axial magnetic field from the cathode of the electron gun to the entrance into the electron collector.
- To get an electron beam with $\sigma=0.8$ mm in the interaction region one needs to have the ratio of magnetic fields in the interaction region to the cathode of 2.52. The field in the interaction region should be as high as possible to provide "rigidity" of the beam. The available power allows us to have maximum magnetic field on the cathode of 8 kG, which leaves us with approximately 2 T field in the interaction region, which is barely sufficient.

Motivation of project (3)

- The available electrical and cooling power of 500 kW at the location of these e-lenses is barely enough for operation of the e-lenses in the “nominal” regime with maximum magnetic field on a cathode of the electron gun 8 kG.
- Extending the range of the electron beam radius and “rigidity” of the central magnetic field would require operating in a “maximum” regime with total power in excess of 1 MW.
- Extending the power capability to this range would take substantial capital investment and time.

	Parameter	Gun coil (GS1)	Gun-transition coil (GS2)	Gun bending coil (GSB)	X-Dipole coil (GSX)	Y-Dipole coil (GSY)
Conductor	h_cond (mm)	14.0	14.0	14.0	6.35	6.35
	ID_water (mm)	9.0	9.0	9.0	4.75	4.75
	B_insul (mm)	0.3	0.3	0.3	0.65	0.65
Dimensions	ID (mm)	173.48	234.0	480.0	178.0	193.0
	OD (mm)	553.08	526.0	859.6	192.0	207.0
	Length (mm)	262.8	379.6	262.8	580.0	580.0
	N_layers	13	10	13	12	12
	N_pancakes	9	13	9		
Nominal regime						
M - field	B (Gauss)	8000.0	4468.0	3202.0	160.0 (5mm)	160.0 (5mm)
Power	P (watt)	58.0	25.6	45.0	1.2	1.5
Current	I (A)	1188.0	731.0	769.0	239.0	258.0
Total power consumed by all magnets in 2 E-lenses (kwatt)						525.2
Maximum regime (nominal+40%)						
M - field	B (Gauss)	11200.0	6256.0	4482.0		
Power	P (watt)	114.0	50.0	88	2.4	3.0
Current	I (A)	1663.0	1023.0	1077.0	334.0	361
Total power consumed by all magnets in 2 E-lenses (kwatt)						1029.6

Motivation of project (4)

- Solenoids powered with copper coils provide the simplest and most inexpensive way to obtain axial magnetic fields.
- One option is to use solenoids with coils made with superconductors operating at ~ 4 K.
- Depending of field, capital cost of NbTi or Nb₃Sn magnets $>$ Cu magnets.
- MgB₂ solenoids cooled by return (exhaust) helium gas of LTS solenoids without the need of adding new cryogenic facilities.

- **Therefore 10-25K MgB₂ solenoids can potentially allow the full optimization of e-lens system currently limited by the availability of power to energize copper solenoids**

- Also, with MgB₂ magnets BNL could realize savings in operating costs (electricity), and minimize the capital costs from upgrading infrastructure (transformers, switch gear, breakers, etc.).

Background on MgB₂ superconductors

- Superconductivity in MgB₂ was publicly announced in January 2001 by Japanese scientists

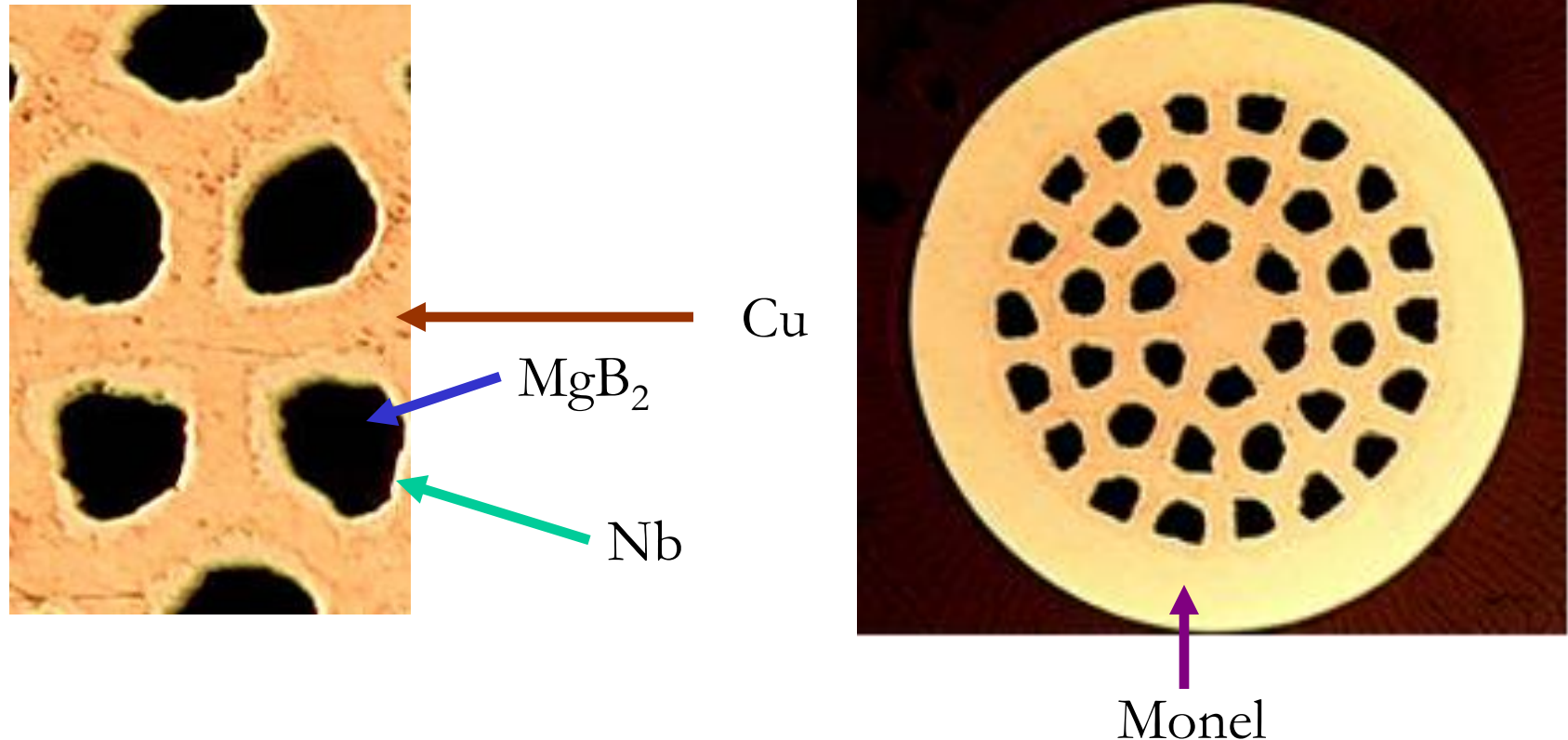

Lengths currently up to 5 km @ 0.8 mm, scaling up to over 60 km.

Manufacturing capabilities

Newly Added Process Equipment for “Wind and React” and “React and Wind” coils:

- Welded seam CTFF process for mono- and multi-filament wire (one shift 10,000 km/yr capacity)
- Large capacity twisting
- Wire-in-channel soldering
- Insulation braiding
- 1m+ coil winding capacity designed for strain-sensitive wire
- 6 km lengths (currently)
- Equipment in place for 60+km lengths
- Large conduction cooled coil testing available

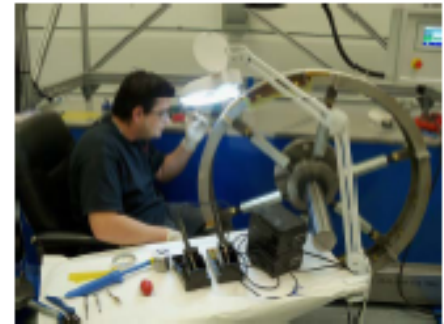

MgB₂ strand recipe: critical current

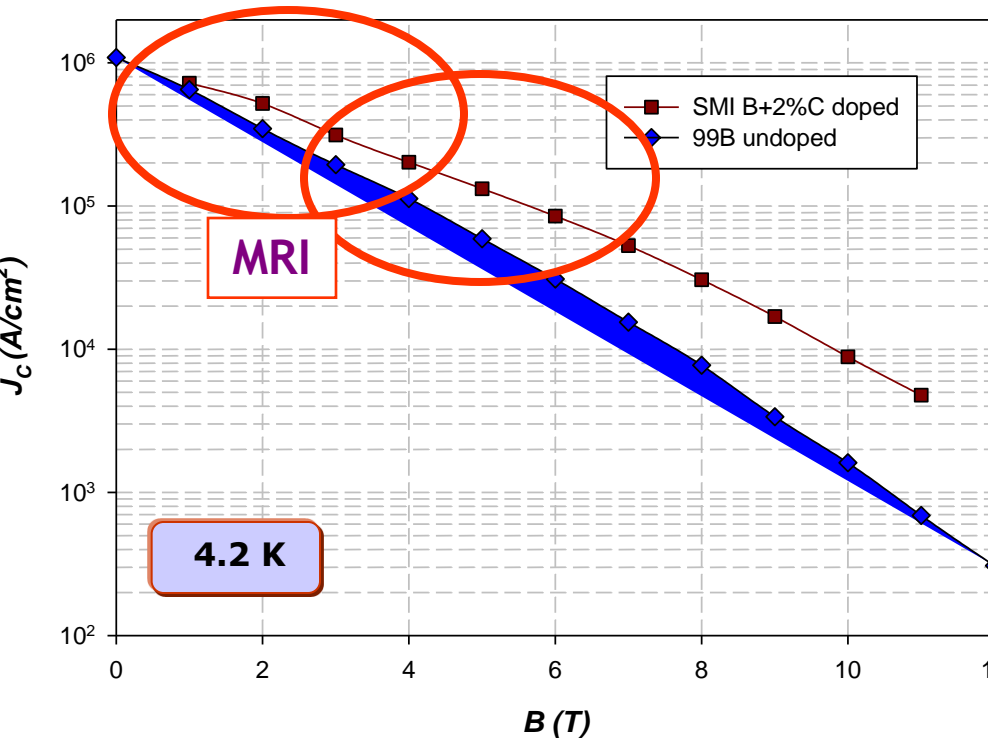

C-doped
MgB₂
I_c based on
15% f.f.

4 K, 4 T:
J_c = 200,000 A/cm²
I_c = 245 A (0.83 mm)

20 K, 1 T:
J_c = 300,000 A/cm²
I_c = 350 A (1 mm)

Commercial magnet pull: MRI & FCL

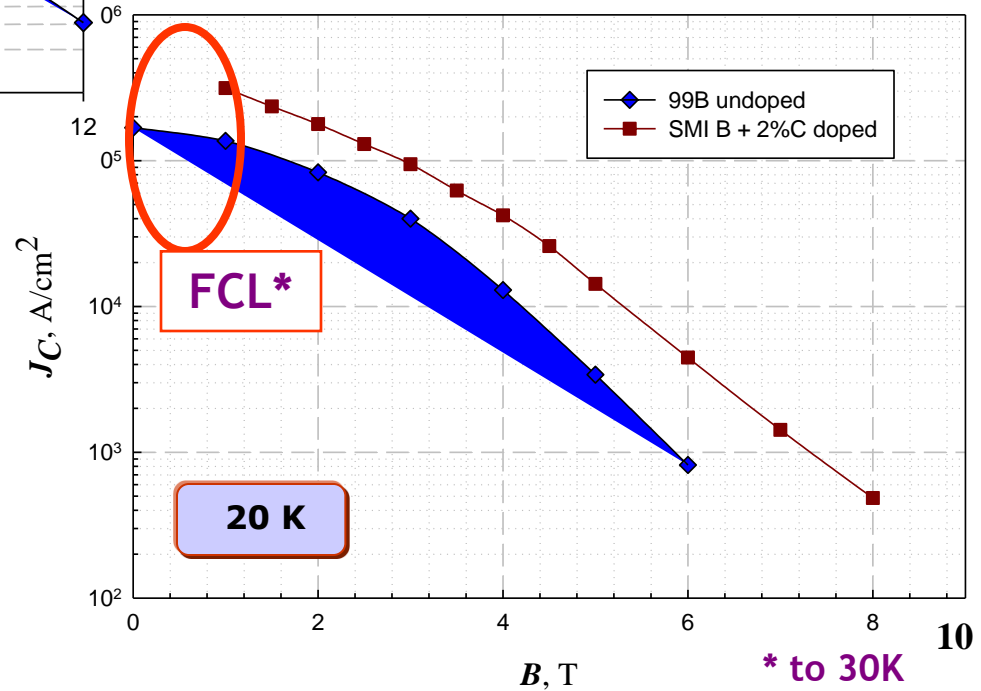
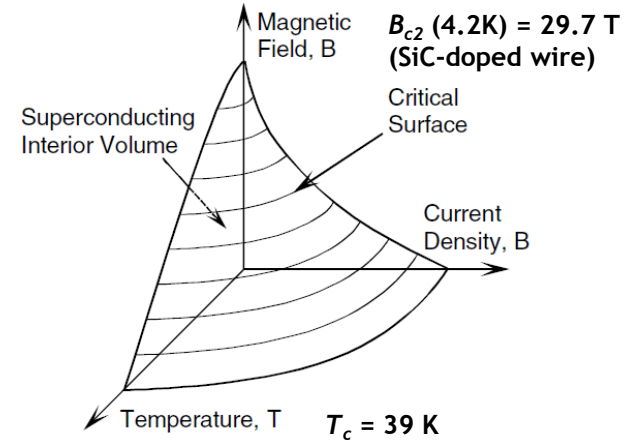

MgB₂ superconductor applications

Superconducting Fault Current Limiter

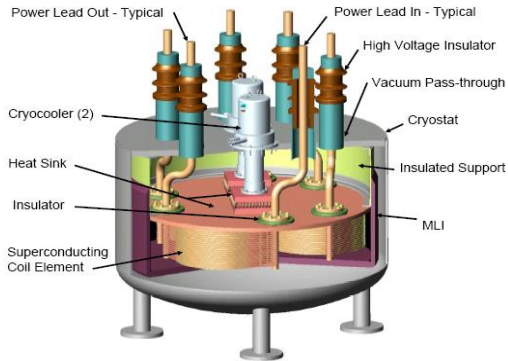

5-20MW
wind
turbine

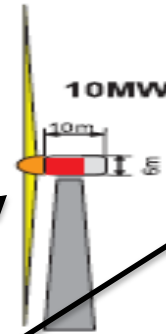

1.5 & 3.0 T MRI

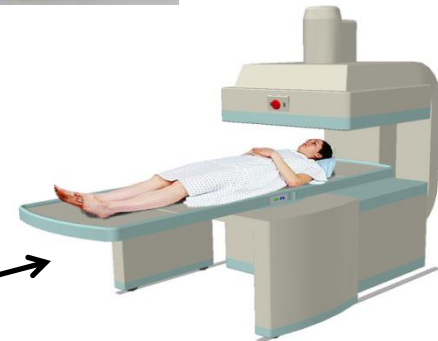

Specialty MRI

Custom MgB₂
MRI magnet

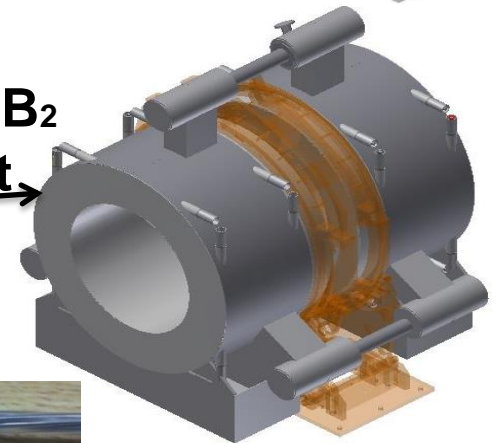

DC Cables

MgB₂
Superconducting
Wire



MRI applications

Hyper Tech Magnesium Diboride superconductors enables liquid helium free magnets.

MRI manufacturers' have stated MgB_2 wire is the only option in the time frame that is needed to convert to non-helium bath cooling.

\$50 million industry effort to convert to MgB_2 .

We are currently working with 5 MRI manufacturers.

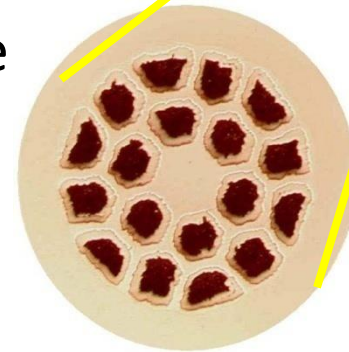
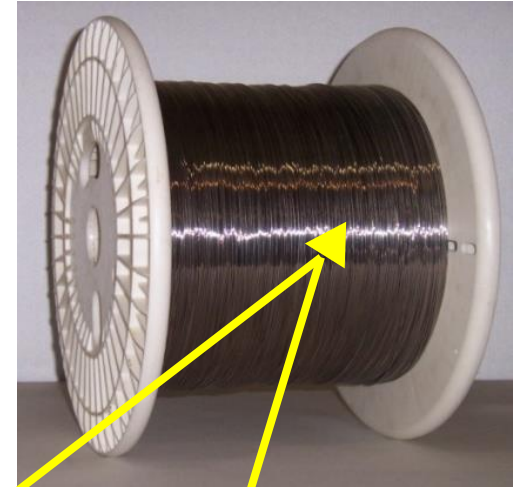

Availability of helium

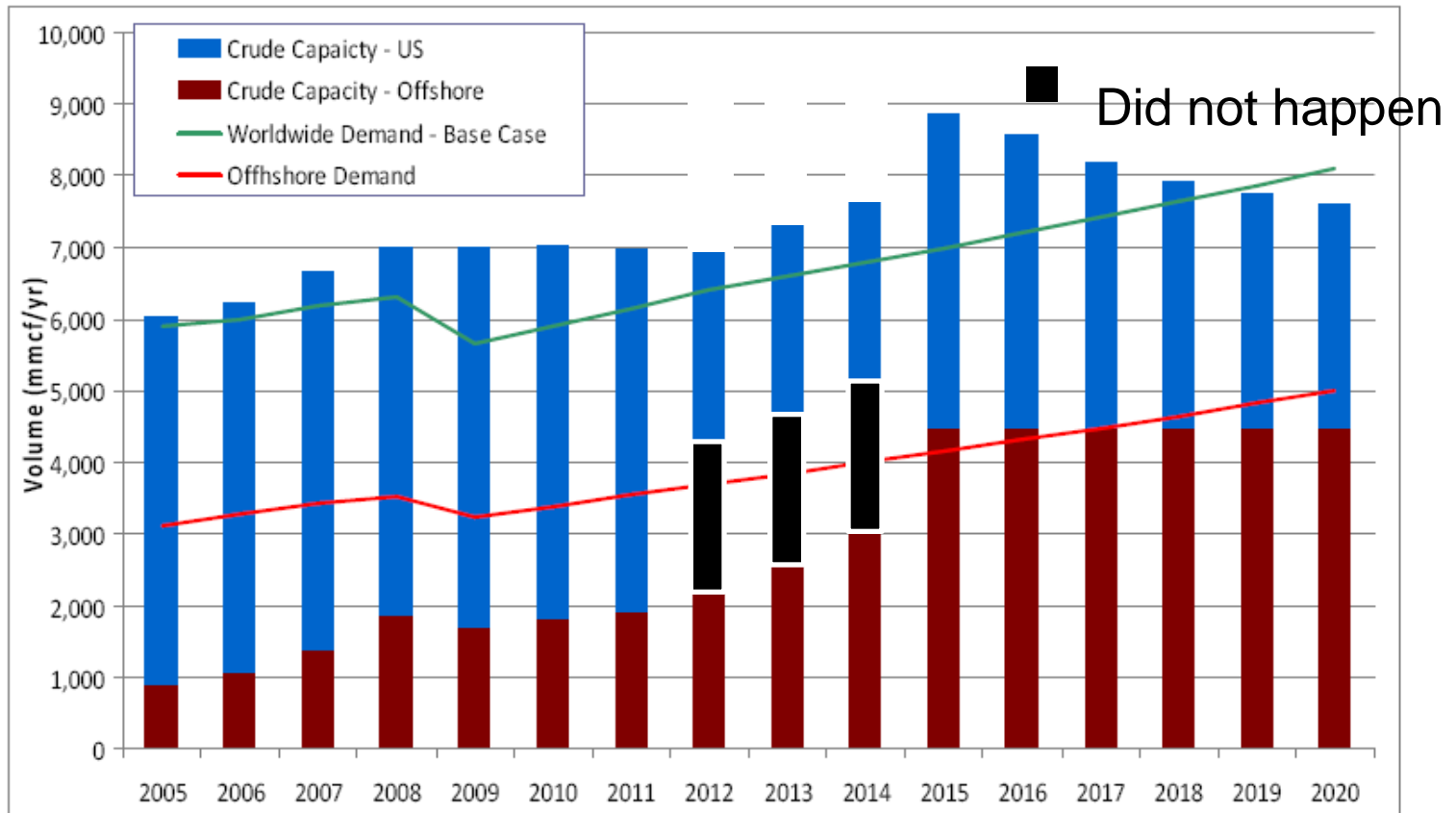

Cost of helium increasing rapidly because U.S. Strategic Reserve being depleted

Helium shortage worldwide predicted, present situation is worse than 2009 NAS report

Advantages of MgB₂ to MRI Manufacturers

Statement by MRI manufacturer: "We will commercialize regardless of liquid helium price increases" because:

Safety:

- Immune from helium vessel ruptures.
- Magnet requires no special measures to prevent helium from entering examination room.

Cost (lower cost MRI magnet system):

- Lower manufacturing cost due to fewer components.
- Reduced site cost: no quench infrastructure.
- No liquid helium replenishment on installation or in service if magnet quenches.
- No air shipping of magnets filled with liquid helium.

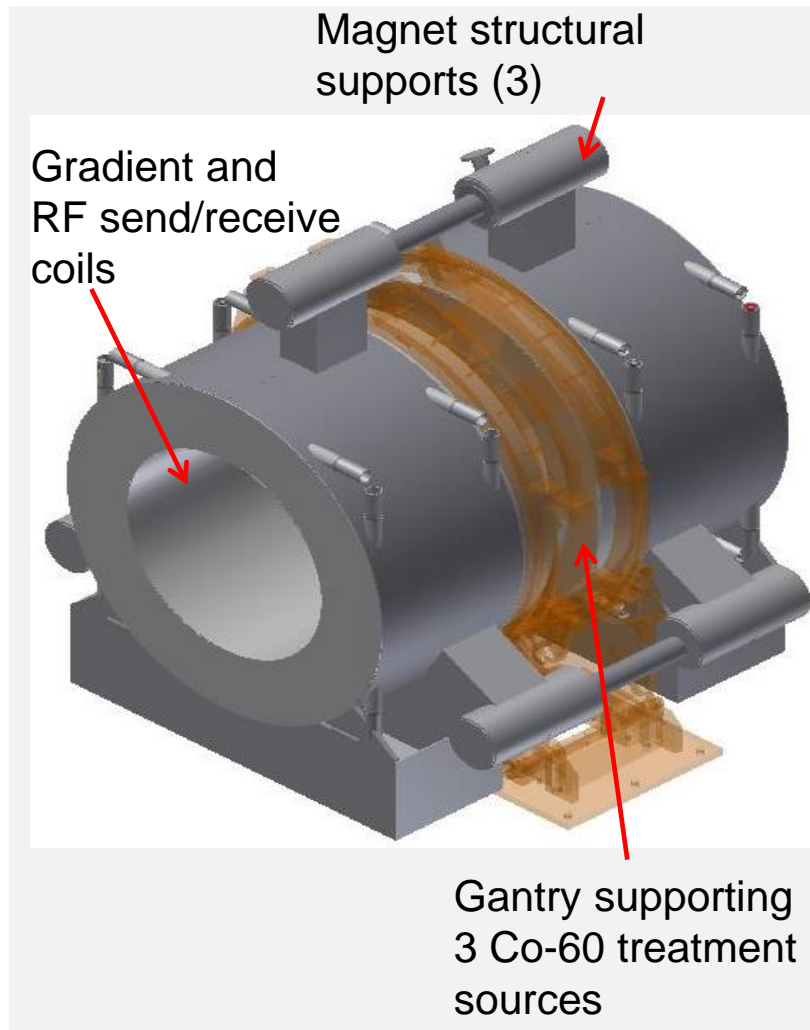

MgB₂ Image Guided Radiation Treatment Medical System

Motors and generators

Advantages of MgB_2 :

- Reduction of size and weight of machine
- No joints in rotor pole (long length conductor)
- Faster normal zone propagation
- Meets current density requirements ($< 4\text{T}$)
- Made round to be easier to configure into complex coil geometries
- Significant reduction of cost
- Persistent coils

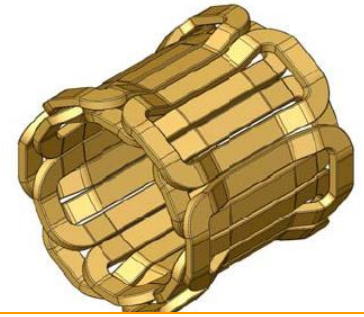
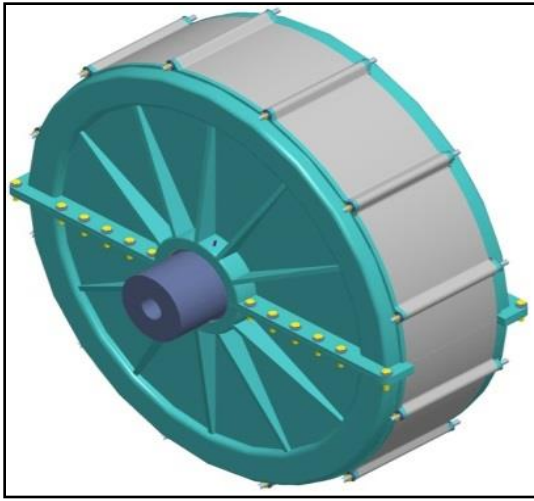

Concepts and projects using MgB_2 :

- Hyper Tech has designed a modular 5 MW land based direct drive wind turbine generator that is transportable, sponsored by **DOE**
- All cryogenic 10 MW Superconducting wind turbine rotor and stator, S. Kalsi (2014 *IEEE Transactions of Applied Superconductivity* **24**)
- **NASA 1 MW demonstrator**
- **Studies in Europe, including Airbus & Rolls Royce**

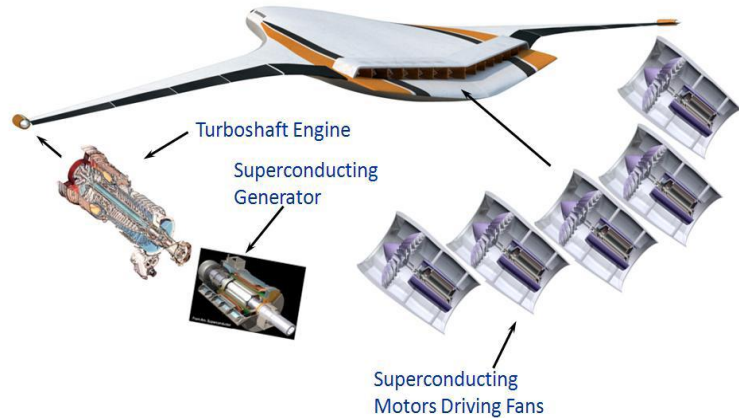

MgB₂ Fault Current Limiter

Coil for resistive SFCL



Coil for inductive SFCL

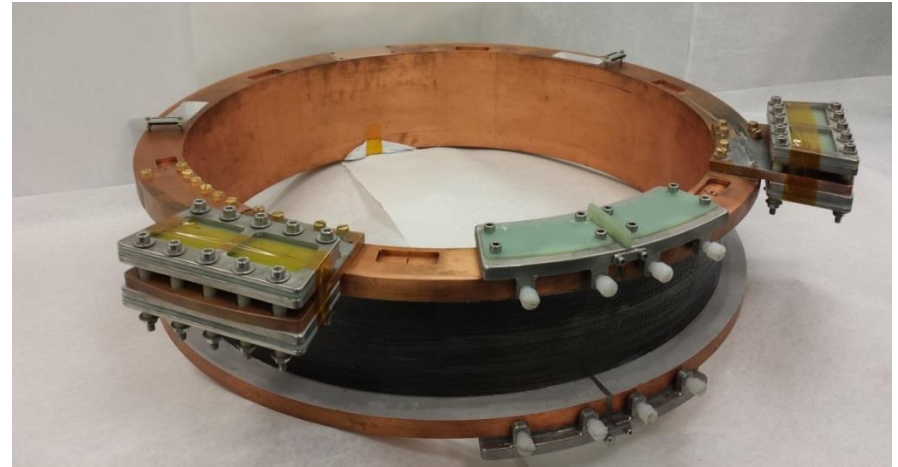

Conduction cooled cryostat at Ohio State University for testing both inductive and resistive SFCL coils

Advantages of MgB₂:

- Low cost wire, much lower than HTS
- Can vary thermal conductivity by wide choice of resistive & conductive materials
- Is in a wire form that can be wound bi-filar and can be twisted and/or braided to reduce AC loss
- Is readily available in quantity and lengths
- Wire can be sized to designed current level

SBIR Phase II objectives

- **Demonstrate [MgB₂] technology to the National Laboratories**
- BNL will model and design larger appropriate MgB₂ coils for Nuclear Physics needs
- Hyper Tech will conduct R&D to develop the fabrication techniques for these MgB₂ coils
- Hyper Tech will build several MgB₂ coils
- BNL will incorporate these coils into their test cryostat
- BNL will carry out extensive life cycle testing of the MgB₂ coils over a large number of power, quench and thermal cycles and finally perform field quality measurements and other rigorous evaluation to confirm that coil performance and reliability is appropriate for this Nuclear Physics and other future accelerator facilities.

Modeling for MgB₂ solenoids (1)

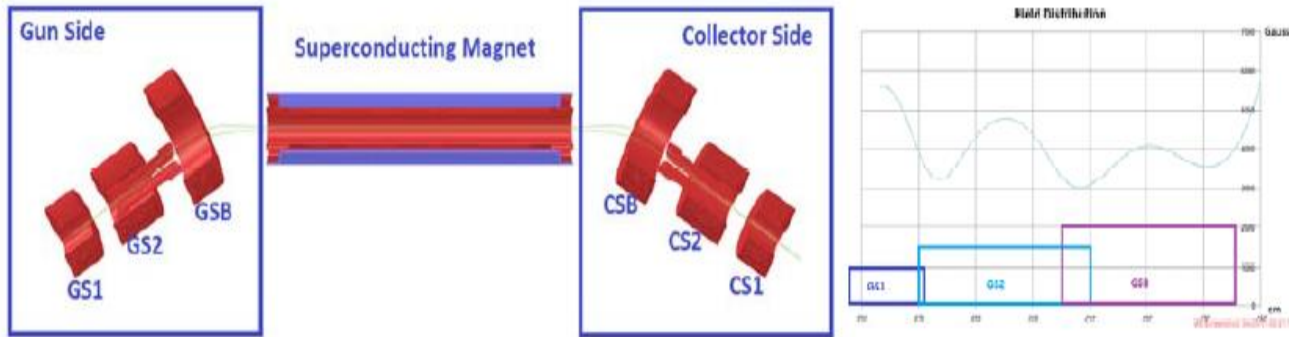

Magnetic model of the basic e-lens system showing copper solenoids and a dipole coil on either side of the superconducting solenoid (right) and magnetic field in Gauss along the central trajectory (right)

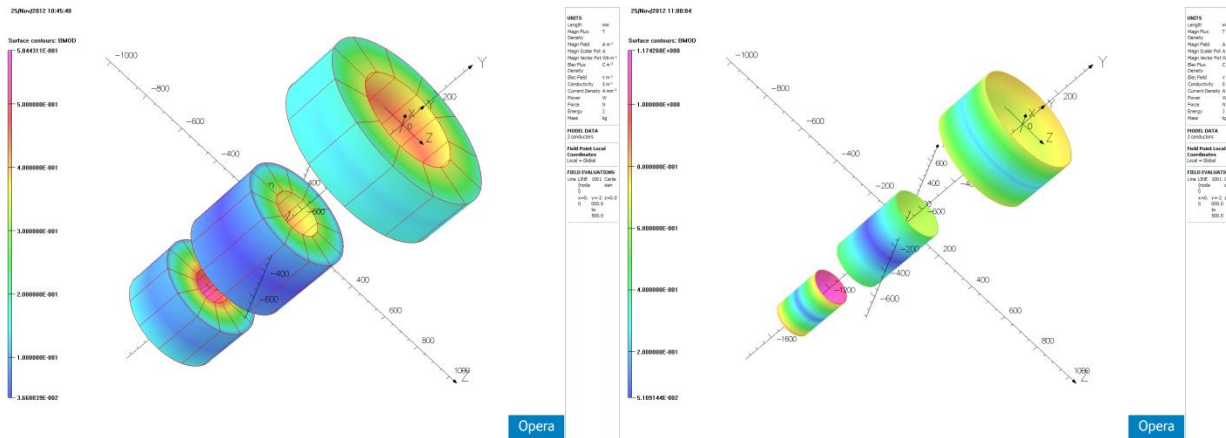

Field in Tesla superimposed on the Cu coils on left and MgB₂ coils on right.

Modeling for MgB₂ solenoids (2)

25/Nov/2012 11:02:07

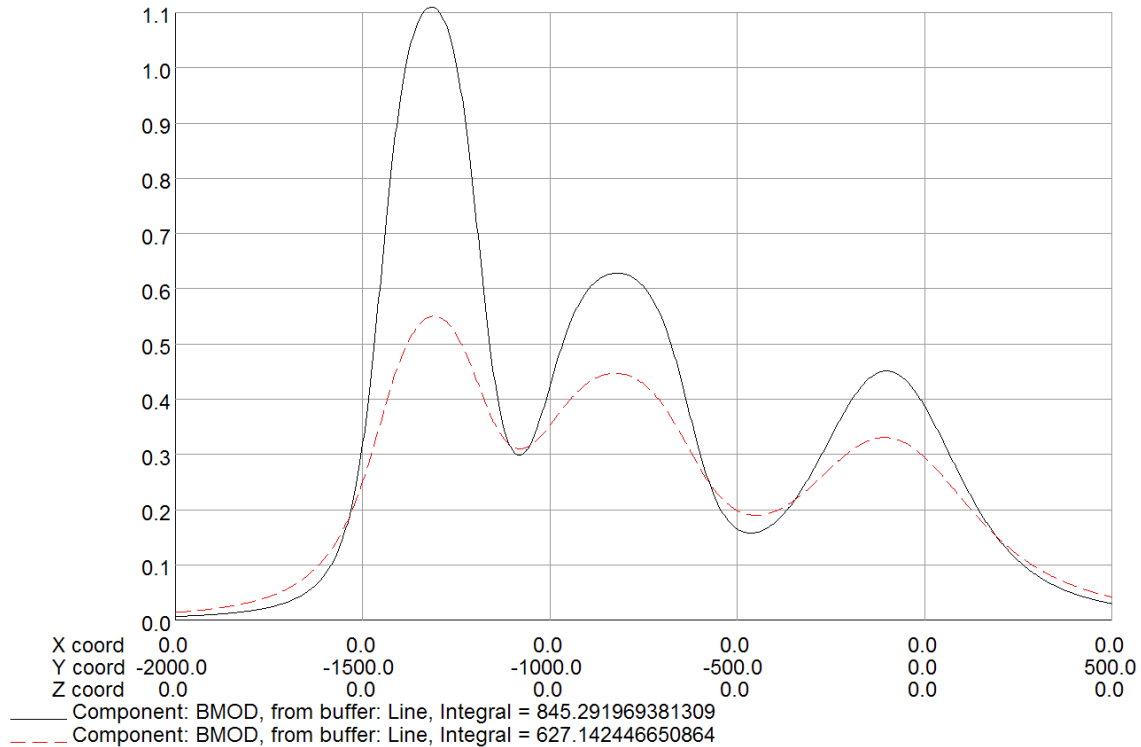

UNITS	
Length	mm
Magn Flux	T
Density	
Magn Field	A m ⁻¹
Magn Scalar Pot A	
Magn Vector Pot Wb m ⁻¹	
Elec Flux	C m ⁻²
Density	
Elec Field	V m ⁻¹
Conductivity	S m ⁻¹
Current Density	A mm ⁻²
Power	W
Force	N
Energy	J
Mass	kg

MODEL DATA	
3 conductors	

Field Point Local Coordinates	
Local = Global	

FIELD EVALUATIONS	
Line	LINE 1001 Carte
(node	slan
)	
x=0,	y=-2 z=0.0
0	000.0
to	500.0

Opera

Field in Tesla on the axis created by MgB₂ coils (solid black) and copper coils (dash red) in RHIC e-lens system.

Coil #1 (based on GS1)

“Ball-park” parameters of MgB₂ for GS1 coil producing 1 T

GS1 Starting Parameters		
Amp.turns	260000	260000
Amp	200	100
turns	1300	2600
IR(m)	0.088	0.088
Radial Spacing (mm), approx	1	1
Axial spacing (mm), approx	1	1
Joverall (A/mm ²)	200	100
Length of the Solenoid (m)	0.263	0.263
Number of Layers	5	10
Number of turns/layer	260	260
OR (m)	0.091	0.093
Average radius	0.089	0.091
Average circumference (m)	0.560	0.568
Conductor Length(m)	729	1478
Approximate Cost/m(\$)?	10	10
Approximate Total cost (\$)	7286	14777

Actual parameters of MgB₂ solenoid

- **B₀ = 0.7 T (15 K)**
- **86 A**
- **J_e = 170 A/mm² (15 K)**
- **IR = 0.0876 m**
- **Length of solenoid = 0.263 m**
- **2180 turns**
- **8 layers**
- **272.5 turns/layer**
- **Conductor length = 1229 m**

Coil #1 fabrication

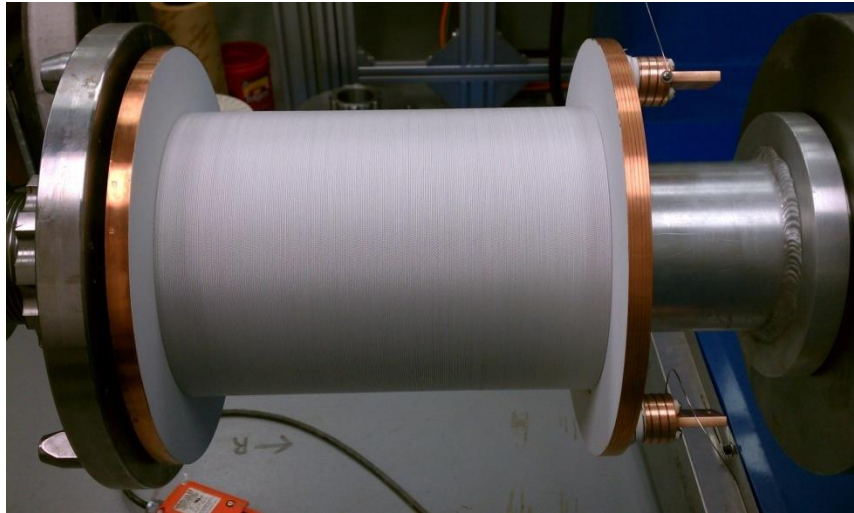

On winding machine

After epoxy impregnation



Coil #1 – characterization at OSU

Coil dewar internal assembly



Coil instrumentation schematic

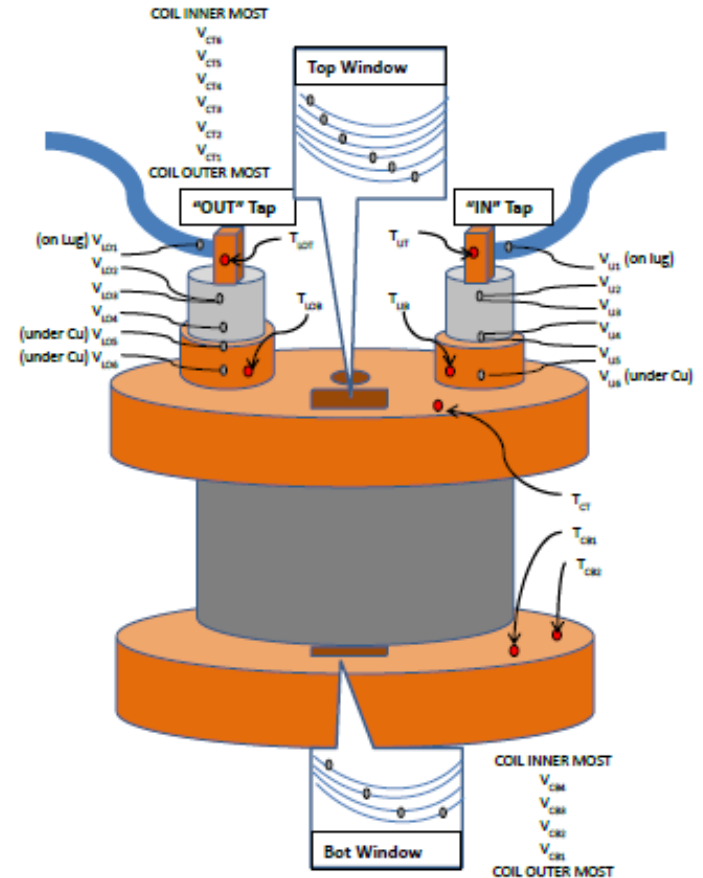

Coil #1 – characterization results

HyperTech/OSU/BNL MgB₂ Coil for eRHIC

I_c @ 0.1 $\mu\text{V}/\text{cm}$ in 2nd Layer

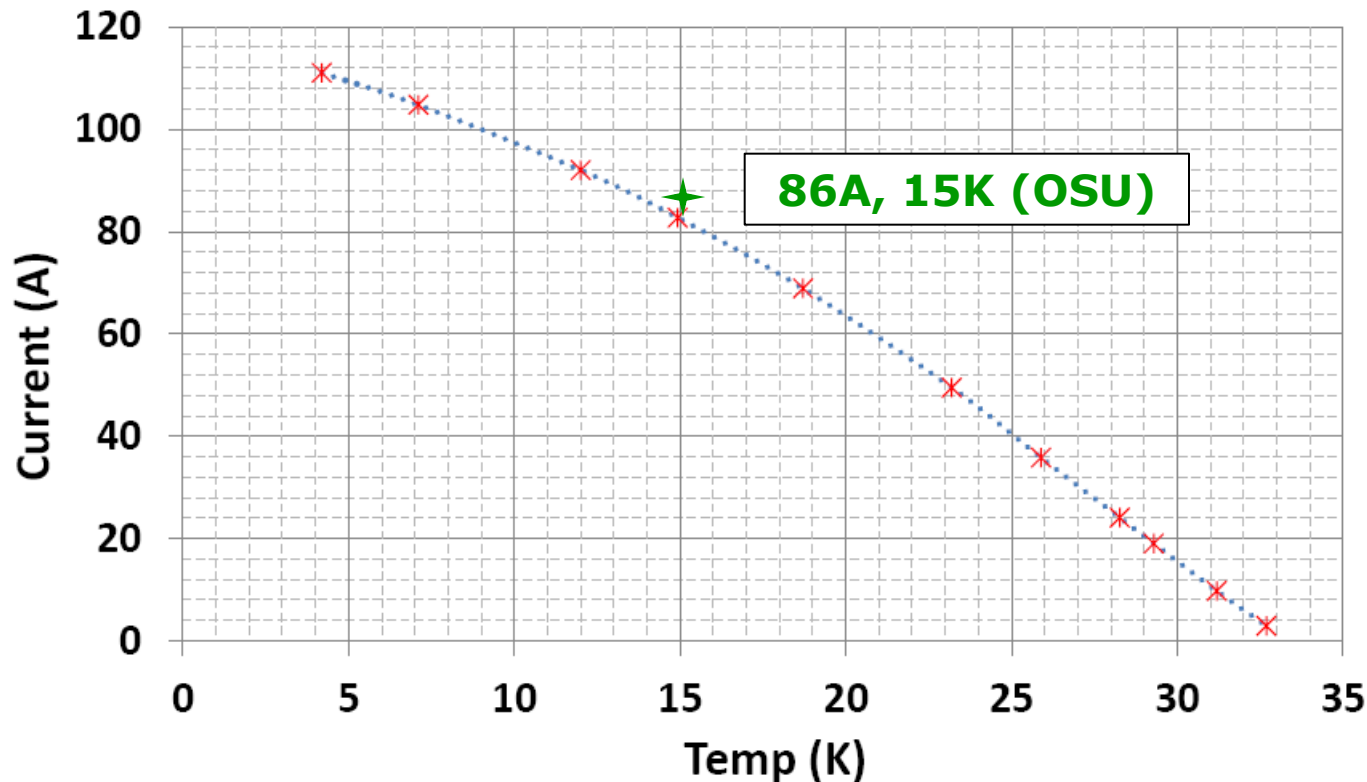

Brookhaven successfully measured coil, closely matching OSU's results

Coil #2 (“react and wind”)

18” demonstration conductively-cooled “React and Wind” coil

- $I_c = 152 \text{ A}$ (20 K)
- $J_e = 275 \text{ A/mm}^2$ (20 K)
- $B_w = 0.83 \text{ T}$ (20 K)
- $B_0 = 0.15 \text{ T}$ (20 K)
- Coil ID = 0.46 m (18”)
- Coil height = 20 mm
- 225 turns
- 12 layers
- 19 turns/layer
- Conductor length = 406 m
- Conductor $\Phi = 0.84 \text{ mm}$

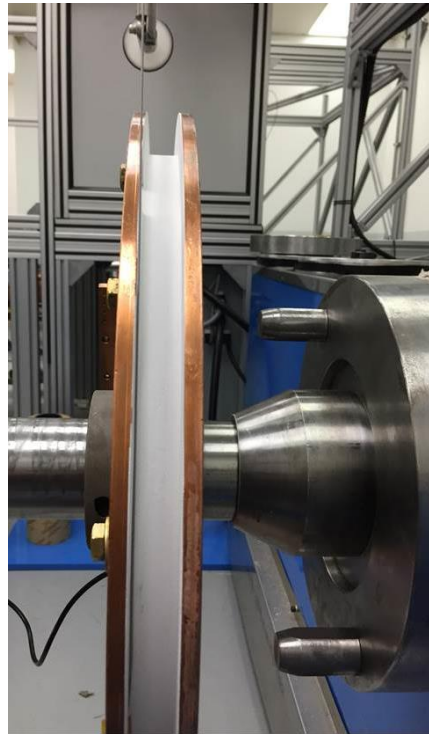

On winding machine



After epoxy impregnation

Coil #2 – characterization results

Technology developed for “React and Wind” large coils: smooth transition terminations, controlled tension coil winding, epoxy impregnation, cool down, and testing.

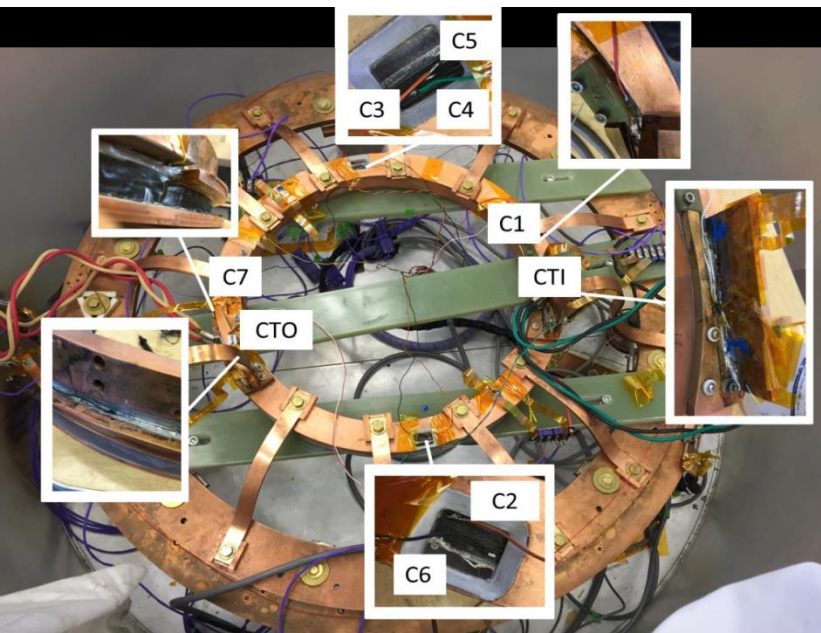

As instrumented in cryostat
at OSU

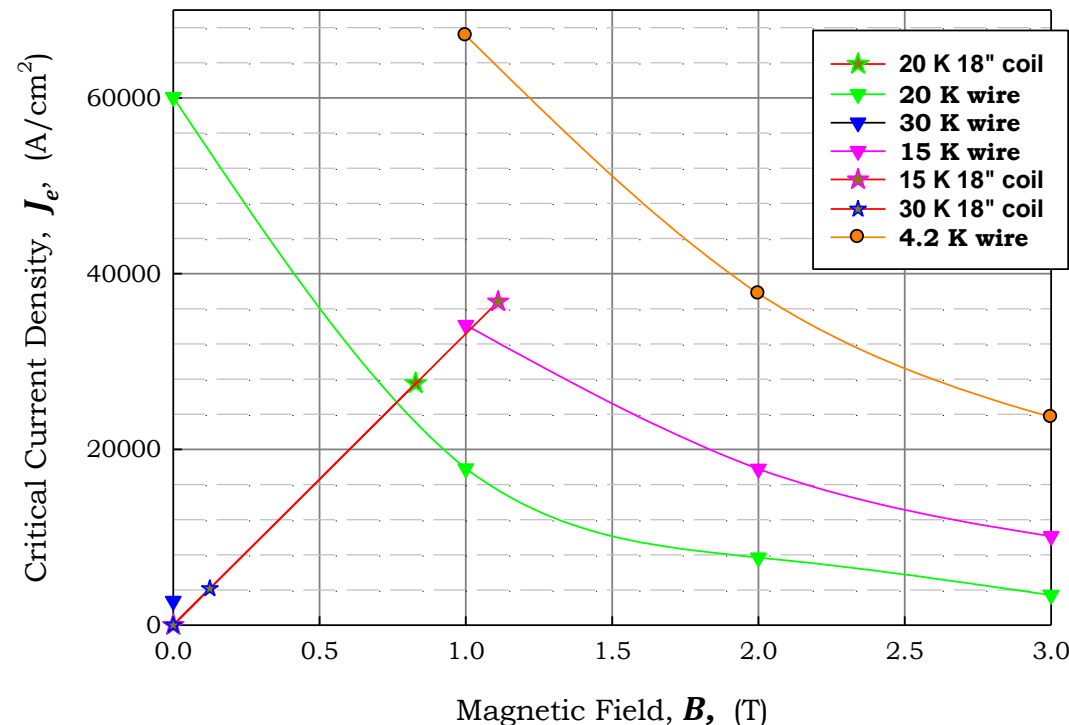

Coil load line shows that coil
out-performed short sample
at 15K, 20K and 30K!

Next steps

- **Life time cycle tests will be performed on the R&W MgB₂ coil (#2) at BNL:**
 - Power up and down cycle to 90% of the short sample
 - Thermal cycles
 - Over-current cycle hitting quench detection threshold. It is important to learn that the model coils developed in the Phase II are robust enough to handle quenches non-destructively.
 - Quench propagation and other related studies
- **3rd coil based on GS coil**
 - React and wind technology vs. W & R
 - Conduction cooled
 - Longer conductor piece length, i.e, 1500 – 2000 meters

----- *thank you for your attention*